



this  
is

# AT THE AUPE

WELCOME  
TO YOUR  
UNION



**AUPE** 

To represent  
and support  
AUPE members  
through solidarity  
and mobilization.

ALBERTA UNION OF PROVINCIAL EMPLOYEES  
MISSION STATEMENT



# **THIS IS AUPE**

## WELCOME TO YOUR UNION

WELCOME TO YOUR UNION . . . . .	5
KEEP IN TOUCH . . . . .	6
GET INVOLVED. . . . .	9
WHAT IS A UNION?. . . . .	12
YOUR COLLECTIVE AGREEMENT. . . . .	15
AUPE UNION STEWARDS - PROTECTING YOU. . . . .	16
HEALTH & SAFETY ACTIVISM . . . . .	21
AUPE SERVICES - FOR MEMBERS ONLY . . . . .	22
UNION FUN - AREA COUNCILS. . . . .	25
AUPE FINANCING. . . . .	28
AUPE STRUCTURE & ACCOUNTABILITY . . . . .	31
AUPE - PAST, PRESENT & FUTURE . . . . .	32
GLOSSARY . . . . .	36
MY AUPE . . . . .	38



# WELCOME TO YOUR UNION

You are now a part of an exciting and growing organization dedicated to standing up for the rights and interests of working people and the services Albertans depend on.

As a new member, it is a lot to take in, especially if you are also starting a new job. This guide will get you started, and over time you will have many opportunities to learn more and get involved in your union.

---

## **Your working people**

You will find fellow AUPE members at work every day in every corner of this province providing a vast range of services to Albertans.

AUPE's more than 95,000 members work hard in all areas of the public, for profit and not for profit sectors. Whether it be in direct frontline government services, nursing and support staff in health care, support and technical staff in post-secondary institutions and schools, or a wide range of positions in boards, agencies, and municipalities, AUPE members help keep our great province running every single day.

## **Your voice at work**

AUPE is a strong and vibrant organization that stands up for its members.

When your safety and rights at work are threatened, AUPE will be there, protecting and representing you on your worksite.

When it comes time to bargain a collective agreement with your employer, AUPE will be there, helping you get fair compensation and benefits.

As frontline workers, AUPE members also stand up for the services Albertans rely on every day. Together, we are some of the most informed and effective advocates for services the people of the province count on.

## **Strength in numbers**

AUPE's strength and success is due to its large and active membership, working alongside dedicated leaders, activists, union stewards and AUPE's professional staff.

You will have many opportunities to get involved with your union as much as you want to, whether it is at your worksite, your chapter or local, or through union education programs.

The support and involvement of members like you is what makes AUPE the strong, democratic organization it is today. Our strength in numbers has enabled AUPE to be a powerful voice on issues that matter to working people.

This is AUPE. Welcome to your union. We look forward to working with you!

# KEEP IN TOUCH

All workers want to know what's going on in their workplace, be it good news or bad.

AUPE works hard to keep you fully informed of any changes to your job and workplace, but we need to know how to get a hold of you!

Within the first few months of becoming a member, you will get a "Grey Card" in the mail. That card affirms that you are a member of AUPE, and gives you a chance to let us know how to get a hold of you. Just fill in the card (including a phone number and personal e-mail address), drop it in the mail and you can rest easy knowing that you will be in the loop!

---

## Member Resource Centre 1-800-232-7284

Take a moment to save this number. If you ever need help or have a question, you can quickly reach Member Resource Centre agents who are trained to connect you with the information you require.

Call the Member Resource Centre toll-free from 8:30 am to 4:30 pm Monday to Friday or leave a message after hours and an agent will call you back the next business day.

When you need your union, it helps to know you can quickly reach a real person who can answer your question or put you in touch with someone who can help.

## MyAUPE Account

AUPE members have access to a wide-range of online resources that help you stay current with developments that affect you.

AUPE's website is updated daily with news, information and resources. All current collective agreements are also available on

this site. Please visit [aupe.org/user/register](http://aupe.org/user/register) to create an account with your Member ID and sign in to access MyAUPE."

*Direct Impact*, AUPE's monthly digital member magazine, is also available online at [aupe.org/direct-impact](http://aupe.org/direct-impact).

Look for AUPE on social media including Facebook, Instagram and Twitter where members share and discuss topics of interest.

AUPE will also share information about public campaigns through our website, Facebook and Twitter. These campaigns help build public support for the quality services that Albertans need and deserve.

## Contacts

Phone: **1-800-232-7284**

Web: **[www.aupe.org](http://www.aupe.org)**

Facebook: **[www.facebook.com/yourAUPE](https://www.facebook.com/yourAUPE)**

Instagram: **[@\\_aupe\\_](https://www.instagram.com/_aupe_)**

Twitter: **[@\\_AUPE\\_](https://twitter.com/_AUPE_)**







# GET INVOLVED

Attend union meetings and events to stay informed and have your say! AUPE depends on members like you to be effective, democratic and responsive to the needs of our members.

---

As a member of AUPE, you have the opportunity to vote on everything from the contract affecting your workplace, to the leadership elected to represent you, to the union's policies and governing constitution.

Take advantage of AUPE education courses to learn how you can help yourself and your coworkers. As a member, you are entitled to take time off for union business. You can start small, volunteering as a worksite contact to help distribute union information at work, for example.

As you learn more and get more involved, consider joining a committee, becoming a steward, or running for an elected position. The possibilities are endless!

**A good place to start is by taking the *Introduction to your Union* course. Call the Member Resource Centre at 1-800-232-7284 to register.**





# WHAT IS A UNION?

A union is a group of working people who have joined together to deal collectively with employers about issues such as wages, benefits and conditions of work.

With more than 95,000 members working in every corner of this province, AUPE is also an effective advocate for the services Albertans depend on and the rights and wellbeing of working people, their families and communities.

---

The bottom line is that unions work for working people. Union members enjoy more secure jobs, earn more money, have more and better benefits, and get more generous vacations than non-union employees. For women, the benefits of unionization are even clearer, with unionized women in Alberta making approximately 34 per cent more than non-union women.

Unionized workers are protected by their collective bargaining agreement, often called a “CBA” or “contract” for short. Together with our large and active membership, AUPE has negotiated some of the best contracts in the province and successfully fought for the wages, benefits and job security that working Albertans deserve.

Without a union, each employee deals with his or her employer as an individual, without the strength of numbers or the protections of a contract. For example, non-unionized workers can be let go at any time, no matter how long they have been working or how good their performance has been.

Throughout our history, AUPE members have stood together to negotiate important improvements such as wage increases,

benefits, and protection against unfair discipline and dismissal. These victories have helped raise industry standards, indirectly benefiting even non-unionized workers.

As frontline workers, AUPE members have also been effective advocates for the services Albertans depend on and for the rights of all working people. Through collective action and solidarity, AUPE has made a difference in our workplaces and communities.

We have made our voices heard as workers and as citizens, and held our governments and leaders accountable. By becoming involved in AUPE, many members have developed the skills and knowledge necessary to become leaders in their workplaces and communities, speaking out about the issues that matter to working people.

AUPE members support each other in difficult times and celebrate successes together. With AUPE, you are never alone.

All workers deserve a real voice in their workplaces and communities. If you know others who would benefit from joining AUPE, tell them to call the Member Resource Centre and ask to speak to the Organizing Department (1-800-232-7284).





# YOUR COLLECTIVE AGREEMENT

How many days of paid vacation do I get? What happens if my employer asks me to work extra hours?

The answers to these and other important questions about the terms and conditions of your employment can be found in a very important document – your collective agreement.

AUPE members are the eyes and ears of the union at the worksites. By working together to make sure your employer is following the collective agreement, and to make improvements to it through collective bargaining, we ensure that members are treated with respect and dignity at work.

---

A collective agreement is a legally binding contract between a union and an employer that sets the terms and conditions of employment for a specific group of workers or “bargaining unit.” Bargaining units can be very large or small. For example, AUPE negotiates collective agreements for 22,000 direct employees of the Government of Alberta and 38,000 employees of Alberta Health Services. In addition to these huge agreements, AUPE also bargains agreements for units as small as a few dozen members.

Regardless of the size of your bargaining unit, when you join the Alberta Union of Provincial Employees, you are joining the largest, most accessible and most effective union in Alberta. Provisions such as hours of work, seniority, paid vacations and illness leave are part of your working conditions today because of the legacy of decades of union bargaining history.

## **Life cycle of a collective agreement**

Collective agreements are negotiated to cover a specific period of time—typically three or four years. Preparations for

bargaining begin several months before the expiration date, but negotiations usually continue for some time before a new agreement is reached. During that time, the terms of your old agreement remain in effect.

AUPE members participate in the bargaining process by consulting with each other and their union and negotiating with their employer. You can participate by giving feedback on your top priorities for bargaining, joining your negotiating team and voting on your contract.

Members ratify their contract in a secret-ballot vote. If a majority of the bargaining unit’s eligible voting members – and the employer – ratify the agreement, it will come into effect.

But no matter how strong a collective agreement may be, it is only a piece of paper unless members make sure it is upheld. If you believe that any provisions of your collective agreement are not followed in your workplace, it is important you inform AUPE as soon as possible by calling the Member Resource Centre at 1-800-232-7284.

# AUPE UNION STEWARDS – PROTECTING YOU

Union Stewards are union activists who are trained to help other union members resolve a wide range of problems and issues with employers or answer your questions about AUPE.

---

Union Stewards are AUPE members just like you who have received training to assist their coworkers. They are usually your first point of contact with AUPE. Often they work alongside you, so they understand the particular needs and challenges of your worksite. Union Stewards are prepared to assist you if you feel you have been the victim of harassment, unfair discipline or if your employer has been ignoring provisions of your collective agreement to deny you benefits to which you are entitled.

One of the important jobs of Union Stewards is to represent you during disciplinary meetings with management. If your supervisor wants to meet with you, ask if the meeting could lead to discipline. If so, you have the right to have a union representative present. That could be your Union Steward or a Membership Services Officer or other AUPE staff. Your employer must make efforts to hold the meeting at such a time as a union representative can be present.

Often, Union Stewards can resolve workplace problems with ease. However, if a problem proves to be more difficult or a Union Steward is not available, an AUPE Membership Services Officer (MSO) can assist you.

If a problem still cannot be satisfactorily resolved, AUPE's collective agreements provide specific steps for filing a formal complaint called a grievance. Grievances proceed through a defined resolution process that may end with a binding decision by an independent arbitrator.

Call the Member Resource Centre (1-800-232-7284) to speak to a Union Steward or MSO. Never hesitate to bring your concerns to them. This is your right under all AUPE collective agreements. Remember that contacting a union representative is your first line of defense if there should ever be a problem related to your employment.











# HEALTH & SAFETY ACTIVISM

All workers have the right to be safe at work, but workplace hazards are still responsible for far too many injuries and deaths each year. AUPE supports our members to address safety risks at work.

---

Workplace deaths are on the rise in Canada overall and Alberta has the highest per-capita workplace fatality rate in Canada, so the urgent need for improved occupational health and safety is clear. Alberta's Occupational Health and Safety Act requires employers to protect the health and safety of workers and gives all workers the right and legal obligation to refuse to do unsafe work. While this right applies to unionized and non-unionized workers alike, AUPE members know they are not alone when addressing workplace hazards.

If you have concerns about the safety of your workplace, contact a Union Steward immediately. A steward can help document your concerns or put you in touch with a trained occupational health and safety advocate. If you don't know the steward at your worksite, contact the Member Resource Centre at 1-800-232-7284.

AUPE has long been a leader in occupational health and safety (OHS) advocacy, and all AUPE members can get involved to help make safety a priority. In addition to a union-wide OHS Committee, many locals also have their own OHS committees. Some collective agreements require employers to meet regularly with AUPE members to discuss workplace safety issues. Members can also access union education courses to become an OHS advocate.

AUPE contributed to establishing April 28, The International Day of Mourning for Workers Killed or Injured on the Job, as a day observed around the world. Every year on that day, AUPE members gather for a solemn ceremony to remember those we have lost and recommit ourselves to doing everything possible to make sure workers in Alberta and around the world come home from work safe and sound.

# AUPE SERVICES – FOR MEMBERS ONLY

AUPE’s long history and strength in numbers means you can access benefits ranging from member discounts on a wide variety of products and services to top-notch labour relations representation and union education. Whether you have a problem at work, need emergency financial aid or want to develop your own knowledge and skills, AUPE officers and staff are available to help.

---

## Contract negotiations

AUPE has bargained some of the best contracts in the province. Regular wage increases, hours of work, overtime pay, statutory holidays, sick leave, health benefits, layoff and recall rules – all these and many more benefits are won through the negotiations process. As an AUPE member, you will help decide the bargaining goals and priorities, participate in and support the negotiation process and vote on your collective agreement.

## Labour relations

Union Stewards and other union representatives help members understand their collective agreements and defend against unfair discipline, dismissal or other contract violations. Members also have access to union staff with the legal and technical expertise to assist with a wide range of issues including health and safety concerns, disability accommodations, return-to-work plans and Workers’ Compensation matters.

## Union education

AUPE runs an extensive union education program that benefits hundreds of members each year. AUPE members are entitled to time off for union business. Education programs range from introductory courses such as *Introduction to Your Union* and *Contract Interpretation* to Union Steward training to specialized topics such as occupational health and safety.

AUPE also holds a week-long Labour School each year. AUPE education courses can even be used for transfer credits at Athabasca University for a Labour Studies or Human Resources and Labour Relations certificate.

## Organizing

AUPE’s organizing department supports the activities of current members including assisting during bargaining and labour disputes and implementing AUPE campaigns. Organizers also assist other workers who want to come together to form a union at their workplace. As the number of workers represented by AUPE grows, we are better able to establish industry standards and protect important services. Current members are encouraged and supported by organizing staff to get involved, ensuring that AUPE continues to be a vibrant, democratic organization.

## Communications

Keeping our members informed on issues that matter in your worksites and communities is a top priority for AUPE. Members will receive timely information about negotiations and bargaining and other workplace issues. AUPE’s website – [www.aupe.org](http://www.aupe.org) – and social media platforms provide up-to-date information and current collective agreements, and our monthly digital magazine *Direct Impact* keeps members connected to each other with updates on the state of the union

and member profiles from across the province. AUPE also reaches out to all Albertans through public campaigns, raising the profile of the important work you and your co-workers do.

## Members’ Benefits Fund

The Members’ Benefits Benevolent Fund was created to help members with last resort financial assistance. If you face a serious emergency that requires financial assistance, you can seek help from the fund. Each application is considered in strict confidence.

## Member discounts

AUPE has arrangements with many businesses—from hotels to insurance companies to cellular phone service providers—that offer significant savings to AUPE members.

## Bursaries & scholarships

Every year, AUPE distributes thousands of dollars in scholarships and bursaries to members, their families and other students at various post-secondary institutions in Alberta. Some bursaries and scholarships are distributed through the Members Education Assistance Fund and others are distributed by the relevant post-secondary institution.

**For more information visit  
[www.aupe.org](http://www.aupe.org) or call the  
Member Resource Centre at  
1-800-232-7284.**







# UNION FUN – AREA COUNCILS

Membership in AUPE benefits our families and communities in more ways than one. Area Councils are set up geographically to organize family-oriented union social events throughout the year.

---

Throughout the province, Area Councils organize events such as curling bonspiels, Christmas parties and picnics, and provide access to discounted products and services such as movie tickets for members and their families.

AUPE members who belong to Area Councils organize activities using funds provided by AUPE headquarters.

When members and their families get to know each other at social events, they not only have a good time, they also form stronger bonds that carry over to their worksites and build solidarity across AUPE.

Call the Member Resource Centre at 1-800-232-7284 to find out how you can get in touch with your Area Council and join the fun!





# AUPE FINANCING

AUPE is a democratic organization financed and operated by and for its members. Dues are the way union members pool their resources to build collective power.

All members who enjoy the benefits of an AUPE collective agreement and union representation finance the organization by paying dues. AUPE's dues rate is 1.25 per cent of a member's basic salary. For example, for each \$100 that a member makes, \$1.25 goes to the union as dues. The dues rate does not apply to overtime or shift premium pay rates, and the money paid by members in dues is tax-deductible.

Members at worksites that have voted to join AUPE do not pay dues until they are protected by a contract, which they have voted to ratify.

Financing the union through dues ensures members like you have the resources you need when you need them. A worker who needs representation for a work-related problem, for example, is not left to bear the costs alone.

AUPE members control the union's finances, and financial information is available for all members to see. Every year, AUPE members elected as delegates to the union's annual Convention review financial statements and vote to approve the budget. Financial statements are also published each fall on the website ([www.aupe.org](http://www.aupe.org)) and available year-round upon request by members.

## YOUR DUES AT WORK\*

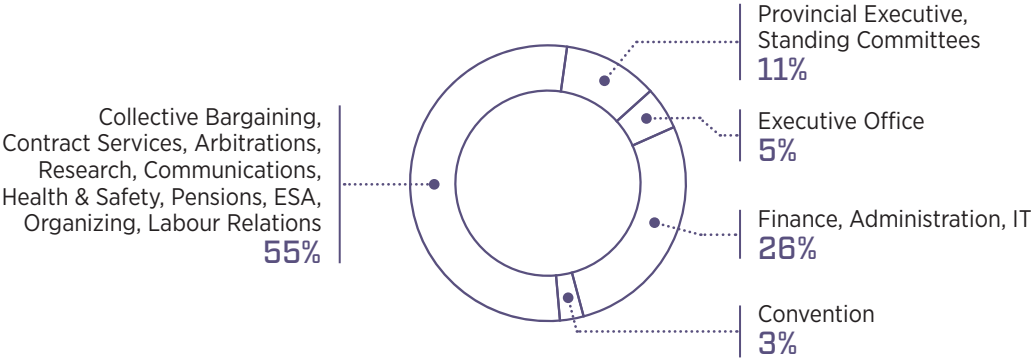

\* These figures are based on the total 2023 AUPE budget.





# AUPE STRUCTURE & ACCOUNTABILITY

AUPE members control the finances and activities of the union themselves by voting at union meetings or serving as an elected representative. Dedicated members keep all parts of AUPE running smoothly, often on a volunteer basis, although paid time off is also arranged to allow them to attend to their duties as required.

## Convention

AUPE's governing body is its Convention – a meeting of delegates from throughout the union that come together in Edmonton every year to set the policies, determine the budget and elect the Executive Committee. Delegates are elected by their fellow members to attend, and each local is entitled to send one delegate for every 100 members.

## Constitution

AUPE's constitution contains the rules by which our union is governed. The AUPE Constitution can only be amended by a vote of not less than two-thirds of the delegates present and voting at the union's Convention.

## Executive Committee

In odd-numbered years, Convention elects an eight-member Executive

Committee made up of the President, the Executive Secretary-Treasurer and six Vice-Presidents. The role of Executive Committee members is to support worksites in their regions, to promote the interests of AUPE members to the general public and the media, and to carry out the day-to-day business of the union.

## Provincial Executive

The Provincial Executive – made up of the Executive Committee and one elected member from each of AUPE's 34 locals – is the governing body of AUPE between Conventions. The Provincial Executive, or PE for short, meets at least six times a year to conduct the business of the union, including advising on key financial and campaign matters. PE is responsible for strategic planning to ensure AUPE remains a strong and growing organization.

## Locals and Chapters

AUPE is organized into locals and chapters to facilitate collective bargaining and contract administration. Members of some locals work at one location in a variety of jobs. Other AUPE locals include a large number of employees who share a "community of interest" across the province or a region. Large or geographically spread-out locals are divided into chapters. Each local and chapter has an elected executive and many also operate committees to focus on areas such as occupational health and safety. For new members, your local and chapter will be your gateway to getting involved in AUPE. Contact the Member Resource Centre to find out how to get in touch with your local and chapter representatives (1-800-232-7284).

## HOW YOU ELECT YOUR UNION REPRESENTATIVES

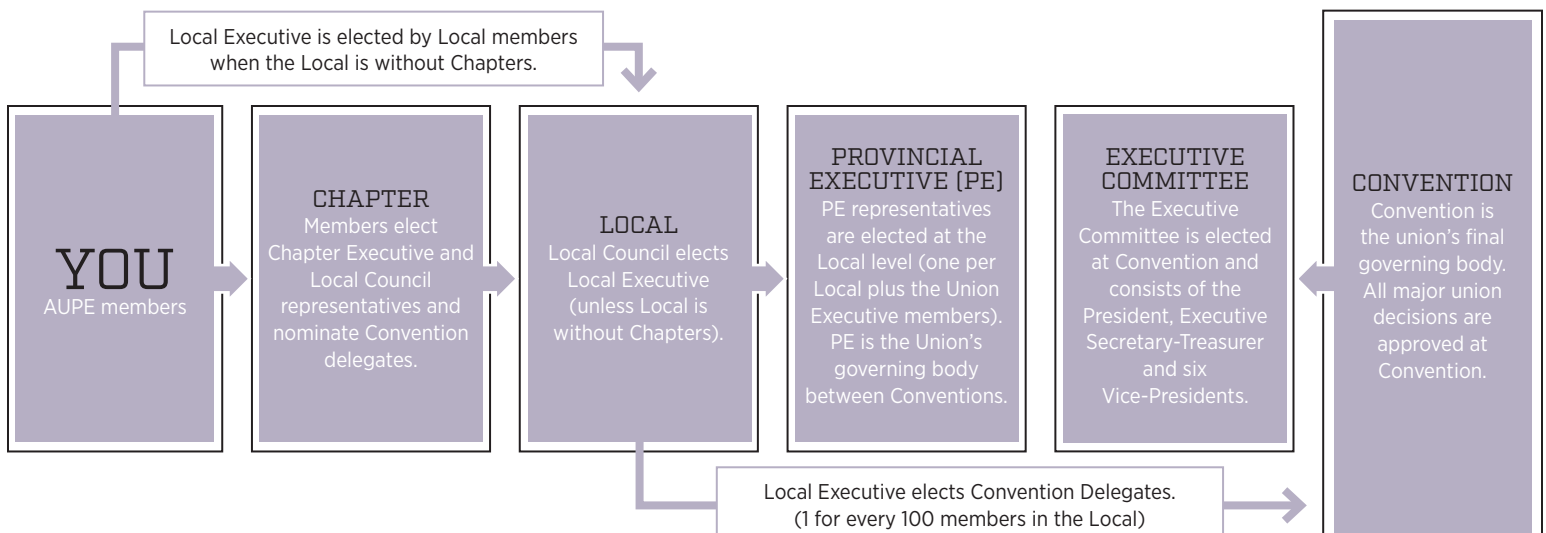

# AUPE - PAST, PRESENT & FUTURE

AUPE is a strong, vibrant and growing union because of the contributions of our past and current members. Our future depends on the next generation of workers delivering the quality services Albertans depend on.

---

AUPE can trace its roots back to 1919 when 400 brave government workers formed the Civil Service Association of Alberta (CSAA) at a time when approaching your supervisor to discuss wage increases was grounds for dismissal. The CSAA remained the only voice of Alberta government employees for almost half a century.

In 1968, the Civil Service Association of Alberta Act severely restricted the organization and its ability to act on behalf of its members. After eight years of lobbying by members, this act was repealed in 1976. The Alberta Union of Provincial Employees was immediately formed, and at a historic Convention in 1977 a new constitution was approved and AUPE was established as an autonomous independent union.

Since that time, AUPE has grown to become Alberta's largest union, representing more than 95,000 members who deliver important services to Albertans throughout the province.

Today, AUPE's members work directly for the provincial government, health care providers, educational facilities, boards and agencies, local governments and private companies in occupations as varied as clerical, technical, corrections, nursing, health facility support roles, social services and environmental protection.

AUPE continues to grow as more and more workers come together in their workplaces to have a voice at work by joining Alberta's largest, most effective and accessible union.

Almost 80 per cent of our members are women, and women from all four sectors of AUPE are involved at every level of the organization. By improving the economic circumstances of our members and providing a supportive environment for women to take on leadership roles, AUPE contributes to advancing the status of women in Alberta.

AUPE's members are as diverse as the jobs they do. They live in cities, small towns and rural areas. They are multi-generational Albertans and newcomers. They work in large institutions and remote field outposts. Nevertheless, common goals unite our members: providing quality services to Albertans, having a voice at work and improving their lives and the lives of their families, communities and all working people.

The future of AUPE depends on our members. Remember, AUPE is your union, and you are AUPE!

## **AUPE is divided into four sectors:**

**Government Services** Over 21,000 of AUPE's members are direct employees of the Government of Alberta.

**Health Care** The nearly 63,000 members of the health care sector are employed by Alberta Health Services, as well as continuing care employers in the public, non-for-profit and private sectors.

**Education** Nearly 11,000 AUPE members work as non-academic staff for Alberta universities, technical institutes, community colleges and school districts.

**Boards, Agencies and Local Government** Over 3,000 AUPE members are employed by boards, agencies and local governments.





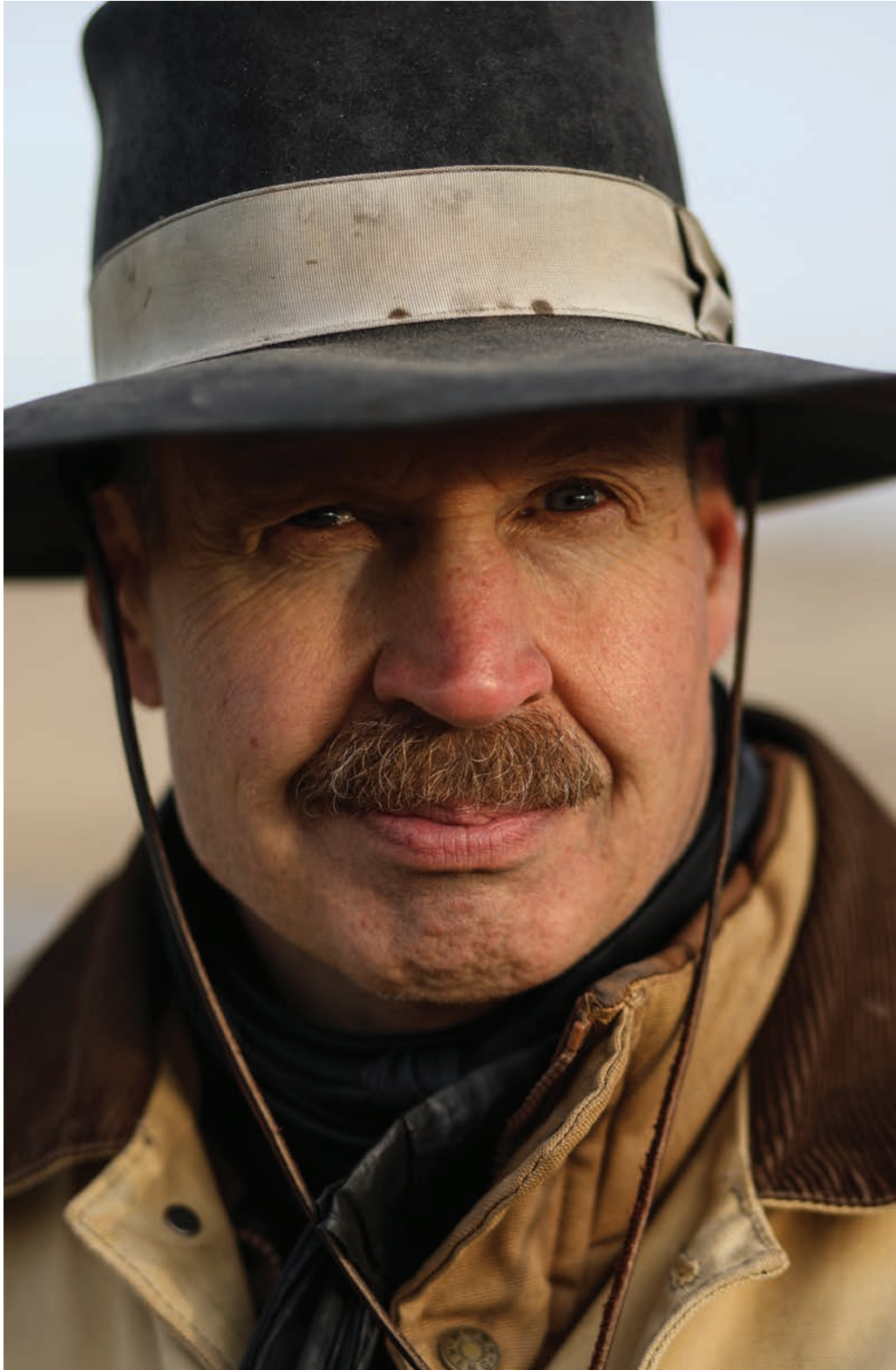



---

# GLOSSARY

**AGM:** see Annual General Meeting

**Annual General Meeting:** yearly meetings of AUPE locals and chapters. Annual General Meetings, or AGMs, are an opportunity for members of a local or chapter to have input on important business such as electing Convention delegates, executive and other representatives, preparing for bargaining, reviewing the past year's finances and activities and planning for the upcoming year.

**Area Council:** a group of AUPE members who volunteer to organize social activities for other members within a geographical area. Area Councils serve the social needs of AUPE members, organizing events such as curling bonspiels, Christmas parties, picnics and other social activities. They receive financing from AUPE headquarters.

**Bargaining unit:** a group of workers certified to bargain collectively with their employers through their union. AUPE has approximately 142 separate bargaining units. Bargaining units can be large or small; for example, AUPE negotiates the largest single collective agreement in Alberta on behalf of approximately 29,000 employees of Alberta Health Services (AHS) General Support Services (GSS). In addition to this contract and other huge agreements, AUPE negotiates with the Government of Alberta, Post-Secondary Institutions, and various public health employers. The union also bargains agreements for working units as small as a few dozen members working in multiple private long term care facilities and in various Boards and Agencies.

**Book-off:** see Time off for union business

**CBA:** see Collective Bargaining Agreement

**Civil Service Association of Alberta:** the precursor organization to AUPE, founded in 1919 to represent government workers. The Civil Service Association of Alberta remained the only voice of Alberta government employees for almost half a century. The Alberta Union of Provincial Employees was founded in 1976 after eight years of lobbying by members for the right to form an autonomous independent union.

**Committees:** see Standing Committees

**Chapter:** - a sub group of AUPE members belonging to the same local. All members of a chapter are protected by the same collective agreement. Each chapter has a democratically elected executive responsible for the chapter's finances and activities.

**Collective Bargaining Agreement:** a legally binding agreement that sets out the terms and conditions of employment at a unionized worksite including wages, wage increases, benefits and other protections. A Collective Bargaining Agreement, often called a "CBA" for short or just a "contract," is like a rulebook that both employees and employers must legally follow. It is set through periodic negotiations between the union and the employer. AUPE members participate in contract negotiations by giving feedback on your top priorities for bargaining, becoming elected to your negotiating team, actively supporting negotiations, and voting on your contract.

**Constitution:** a document that contains the rules by which AUPE is governed. The AUPE Constitution can only be amended by a vote of not less than two-thirds of the delegates present and voting at the union's Convention.

**Contract:** see Collective Bargaining Agreement

**Convention:** AUPE's ultimate governing body. Convention is a meeting held annually where delegates from across AUPE meet in Edmonton. Each local is entitled to send one delegate for every

100 members. At Convention, policy is established, the budget is determined and, in election years, Executive Committee officers are elected by a vote of the delegates.

**CSAA:** see Civil Service Association of Alberta

**Direct Impact:** AUPE's monthly digital member magazine. Direct Impact is mailed to members and is also available online [aupe.org/direct-impact](http://aupe.org/direct-impact).

**Dues:** a percentage of the basic pay of union members paid to the union to fund its operations. Union members protected by a collective agreement pay a percentage of their basic salary to the union. AUPE's dues rate is 1.25 per cent. Dues are the way that union members pool resources to build collective power and ensure that members can access the resources you need when you need them.

**Essential Service Agreement:** The provincial government uses their Essential Services Legislation to limit our ability to strike and our rights during a strike or lockout. An ESA lists services that, in a time of strike or lockout, are needed to protect the life, personal safety or health of the public, or necessary to the maintenance and administration of the rule of law or public security. It's important for you to get involved and participate in ESA consultations. The input you provide us with is our most critical resource. Without it, we're forced to rely on the information the employer provides to us and that would lead to weaker agreements and longer rounds of negotiation.

**Executive:** see Executive Committee

**Executive Committee:** a committee made up of AUPE's President, Executive Secretary-Treasurer and six Vice-Presidents. The members of the Executive Committee are elected in odd-numbered years at the union's Convention. The Executive Secretary-Treasurer is the union's chief financial officer, responsible for financial records and ensuring that expenditures comply with the budget passed at Convention. The President is AUPE's chief executive officer and spokesperson, responsible for assigning duties and responsibilities to other executive officers who support worksites in their regions.

**Discipline:** documentation by an employer or supervisor of alleged misconduct of an employee. If your employer requests a meeting with you that may lead to discipline or you have already received notice of discipline from your employer, contact a union representative immediately. AUPE members have a right to union representation at disciplinary meetings and can request that their union challenge unfair discipline by filing a grievance.

**Grey card:** a document confirming your membership in AUPE and providing contact information to your union. By completing and signing your grey card, you are confirming your membership in AUPE and ensuring that you will be contacted about any important developments in your workplace or your union. All employees at a unionized workplace have a right to union representation even if they have not signed this card; however, if you do not provide contact information to AUPE, it will be difficult to contact you in a timely way.

**Grievance:** a document describing an alleged violation of the rights of one or more employees. A Union Steward or other union representative can initiate grievances on behalf of AUPE members in cases where violations of the rights of one or more employees under the collective agreement have occurred. For example, filing a grievance may be necessary to challenge unfair discipline or dismissal. Grievances proceed through a defined resolution process that may end with a binding decision by a third party arbitrator.

**Labour School:** a week long union education program held each year. Labour School is an opportunity for members who are already active to deepen their knowledge and participation in AUPE and build relationships and solidarity with other members.

**Local:** a group of AUPE members organized into a branch of the larger union. Locals may be made up of all members employed at the same location or employer, members who share a “community of interest” across the province or a region or members doing similar work at many worksites. Large and geographically spread-out locals are divided into chapters. Each local has a democratically elected executive responsible for the local’s finances and activities.

**Member:** a unionized worker represented by AUPE. Workers become AUPE members by becoming employed at a unionized workplace or when a majority of employees at a previously non-union worksite vote to join AUPE. Members have a right to fair representation and have opportunities to get involved in the democratic administration of their union.

**Member number:** a unique number assigned to each member of AUPE. Your AUPE member number is on your membership card. You may need to provide your member number or card in order to access some services offered by AUPE. Providing your member number when calling the Member Resource Centre can help an agent to more efficiently connect you with the information you need.

**Member Resource Centre:** a call centre where AUPE members can quickly reach a real person to direct you to the information and resources you need. AUPE members across Alberta can call 1-800-232-7284 to reach a Member Resource Centre agent Monday to Friday from 8:30 am to 4:30 pm. If you are calling after hours, just leave a message and an agent will call you back the next business day.

**Membership card:** a card issued to all AUPE members. Your membership card lists your name and AUPE member number. You may need to show your membership card in order to access discounts offered to AUPE members by many businesses.

**Membership Services Officer:** a staff member of AUPE who assists members with workplace concerns and labour relations matters. Membership Services Officers, MSOs for short, work together with Union Stewards and may take over on matters that go beyond their scope including grievance handling, contract interpretation, and local and chapter administration. MSOs may also assist with education courses offered to the membership or support collective bargaining.

**MRC:** see Member Resource Centre

**MSO:** see Member Services Officer

**My AUPE Account:** AUPE members have access to a wide range of online resources that help you stay current with developments that affect you. All current collective agreements are available at [aupe.org](http://aupe.org)

**OH&S:** see Occupational Health and Safety

**Occupational Health and Safety:** an area of concern related to the safety, health and welfare of people engaged in work or employment. While all workers have the right to refuse unsafe work, AUPE members are supported to address health and safety concerns related to their employment through education and training, advocacy, provisions in collective agreements and other supports.

**PE:** see Provincial Executive

**Provincial Executive:** the governing body of AUPE between Conventions. The Provincial Executive is made up of the Executive Committee and one elected member from each of AUPE’s 34 Locals. The Provincial Executive, commonly known as PE, meets at least six times a year to conduct the business of the union.

**Representation:** see Union Representation

**Resolution:** a proposal that is debated and voted on at Convention. Delegates at AUPE’s Convention debate and vote on resolutions that reflect the direction the union should take. Resolutions are the only way to change AUPE’s Constitution. Constitutional resolutions must be passed by a majority of at least two-thirds while general resolutions can be passed by 50 per cent plus one vote of the delegates present and voting at Convention.

**Seniority:** an employee’s length of service with an employer, which may be considered in making decisions about wages, layoffs, and other working conditions. Most collective agreements recognize that an employee’s length of service should be a factor in determining some of the terms and conditions of employment. Seniority is not legally protected in non-union worksites, where long-term employees may be paid a rate equal or even less than those hired more recently for the same position. Seniority is often an important factor in collective agreements that have provisions for new hiring and in the case of layoffs.

**Standing Committees:** bodies of AUPE established by the union’s Constitution to advise the Provincial Executive. AUPE has 13 standing committees that work on aspects of the union’s operations and areas of interest to members. A member of the Executive Committee usually chairs the committee and their members are drawn from the membership of AUPE.

**Steward:** see Union Steward

**Time off for union business:** an agreement with an employer that a member will be temporarily released from work in order to attend to activities of the union. Most collective agreements allow for members to take time off work with pay in order to be involved in union activities. When such time off is arranged, AUPE will reimburse the employer for the wages that would be paid for that period of time. Requests for time off usually need to be arranged well in advance and only apply to activities that have been previously approved by the union which members would otherwise be unable to attend.

**Union Representation:** a right that all union members have to be represented by their union, especially when facing potential discipline. If your employer requests a meeting with you that you believe could lead to potential discipline, you have the right to request union representation. Employers are obligated to allow for a Union Steward or other union representative to be present with you in any meeting that may lead to discipline.

**Union Steward:** an AUPE member trained to represent and support other members. Stewards are often the first point of contact for members with their union. They are trained to help members understand their collective agreement and assist with workplace concerns including challenging unfair discipline or dismissal. Any member can become a Union Steward by completing the necessary training.

**Worksite Contact:** an AUPE member who helps to distribute information from the union to his or her coworkers. Becoming a worksite contact is a good way to begin to get involved in AUPE. By receiving and distributing information to your coworkers, you can stay informed about the activities of your union while getting to know other members at your workplace.

# MY AUPE

Make the most of your AUPE membership by staying informed and engaged! Complete this checklist to make sure you haven't missed anything. If you are unsure about anything on this checklist, consult the rest of this magazine or call the Member Resource Centre at 1-800-232-7284.

- Completed and mailed in my grey card
- Create a 'MyAUPE' account at [aupe.org](http://aupe.org)
- Saved the Member Resource Centre number in my phone contacts
- Know the name and contact information of my Union Steward and other worksite contacts
- Received my member card and know my member number
- Visited [www.aupe.org](http://www.aupe.org) and reviewed my collective agreement
- Liked and followed AUPE on Facebook ([www.facebook.com/yourAUPE](http://www.facebook.com/yourAUPE))
- Followed AUPE on Twitter (@\_AUPE\_)
- Know my local and chapter and how to contact them
- Visited the website of my local
- Registered for the *Introduction to My Union* course

## Contact Information

Fill in contact information for your union representatives so you have it handy when you need it.

My Union Steward:
My Worksite Contacts:
My Local:
My Chapter:
My member number:

## Notes

Use this space to write down any questions or concerns that you may have. Contact your Union Steward or call the Member Resource Centre when you have time to get the information you need.

## **We want to hear from you!**

AUPE welcomes your feedback. Let us know if you found this publication useful or if you think it could be improved by emailing [info@aupe.org](mailto:info@aupe.org)

Stay informed! Ensure AUPE has your current contact information.  
Visit: [aupe.org/update-me](http://aupe.org/update-me) to update your contact today!

## Questions?

Call the Member Resource Centre toll-free at 1-800-232-7284

Open Monday – Friday, 8:30 – 4:30  
*Leave a message after hours and an agent  
will call you back the next business day.*

Email: [info@aupe.org](mailto:info@aupe.org)

[www.aupe.org](http://www.aupe.org)



Publications Mail Agreement: 40065207  
RETURN UNDELIVERABLE CANADIAN ADDRESSES TO  
ALBERTA UNION OF PROVINCIAL EMPLOYEES,  
10025 - 182 St. NW, Edmonton, AB T5S 0P7

C23298  
**AULReP**

Sept. 2023